

TWS100X Series

LSOP4, DC Input, Photo Transistor Coupler

Description

The TWS100X series combine an AlGaAs infrared emitting diode as the emitter which is optically coupled to a silicon planar phototransistor detector in a plastic LSOP4 package.

With the robust coplanar double mold structure, TWS100X series provide the most stable isolation feature.

Features

- High isolation 5000 VRMS
- CTR flexibility available see order information
- DC input with transistor output
- Operating temperature range - 55 °C to 110 °C
- RoHS & REACH Compliance
- Halogen free
- MSL class 1

Applications

- Switch mode power supplies
- Programmable controllers
- Household appliances
- Office equipment

SCHEMATIC

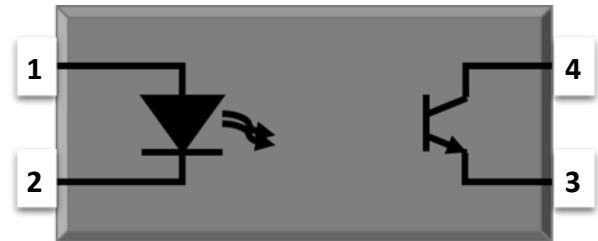

PIN DEFINITION

1. Anode
2. Cathode
3. Emitter
4. Collector

PACKAGE OUTLINE

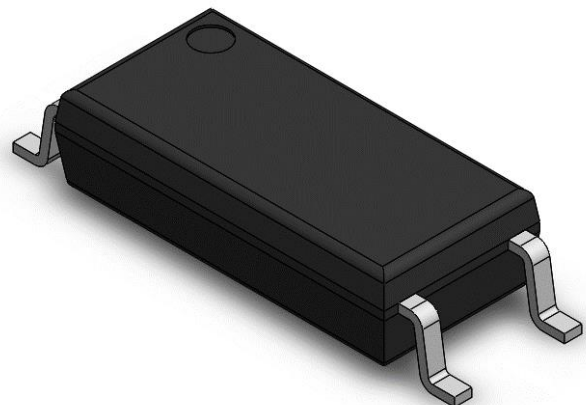

TWS100X Series

LSOP4, DC Input, Photo Transistor Coupler

ABSOLUTE MAXIMUM RATINGS				
PARAMETER	SYMBOL	VALUE	UNIT	NOTE
INPUT				
Forward Current	I_F	60	mA	
Peak Forward Current	I_{FP}	1	A	1
Reverse Voltage	V_R	6	V	
Input Power Dissipation	P_I	100	mW	
OUTPUT				
Collector - Emitter Voltage	V_{CEO}	80	V	
Emitter - Collector Voltage	V_{ECO}	7	V	
Collector Current	I_C	50	mA	
Output Power Dissipation	P_O	150	mW	
COMMON				
Total Power Dissipation	P_{tot}	250	mW	
Isolation Voltage	V_{iso}	5000	V _{rms}	2
Operating Temperature	T_{opr}	-55~110	°C	
Storage Temperature	T_{stg}	-55~125	°C	
Soldering Temperature	T_{sol}	260	°C	

Note 1. 100μs pulse, 100Hz frequency

Note 2. AC For 1 Minute, R.H. = 40 ~ 60%

TWS100X Series

LSOP4, DC Input, Photo Transistor Coupler

ELECTRICAL OPTICAL CHARACTERISTICS at Ta=25°C							
PARAMETER	SYMBOL	MIN.	TYP.	MAX.	UNIT	TEST CONDITION	NOTE
INPUT							
Forward Voltage	V _F	-	1.24	1.4	V	I _F =10mA	
Reverse Current	I _R	-	-	10	μA	V _R =6V	
Input Capacitance	C _{in}	-	30	250	pF	V=0, f=1kHz	
OUTPUT							
Collector Dark Current	I _{CEO}	-	-	100	nA	V _{CE} =20V, I _F =0	
Collector-Emitter Breakdown Voltage	BV _{CEO}	80	-	-	V	I _C =0.1mA, I _F =0	
Emitter-Collector Breakdown Voltage	BV _{ECO}	7	-	-	V	I _E =0.1mA, I _F =0	
TRANSFER CHARACTERISTICS							
Current Transfer Ratio	TWS1007 TWS1008 TWS1009	CTR	80	-	160	%	I _F =5mA, V _{CE} =5V
			130	-	260		
			200	-	400		
Collector-Emitter Saturation Voltage	V _{CE(sat)}	-	0.1	0.3	V	I _F =10mA, I _C =1mA	
Isolation Resistance	R _{ISO}	10 ¹²	10 ¹⁴	-	Ω	DC500V, 40 ~ 60% R.H.	
Floating Capacitance	C _{IO}	-	0.4	1	pF	V=0, f=1MHz	
Cut-off Frequency	F _c	-	80	-	kHz	V _{CE} =2V, I _C =2mA R _L =100Ω, -3dB	3
Response Time (Rise)	Tr	-	5	18	μs	V _{CE} =2V, I _C =2mA	4
Response Time (Fall)	Tf	-	6	18	μs	R _L =100Ω	4

Note 3. Fig.12&13

Note 4. Fig.14

CHARACTERISTIC CURVES

Fig.1 Forward Current vs. Ambient Temperature

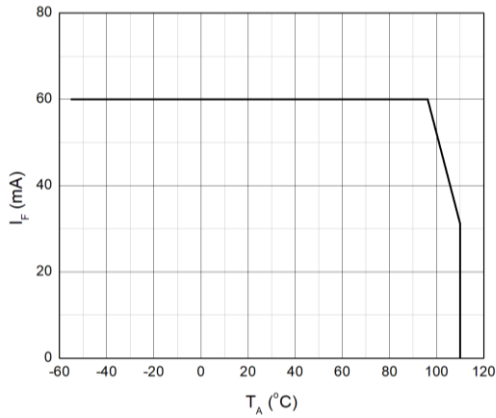

Fig.2 Collector Power Dissipation vs. Ambient Temperature

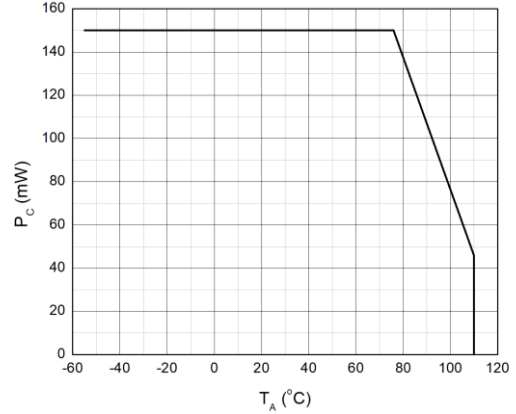

Fig.3 Forward Current vs. Forward Voltage

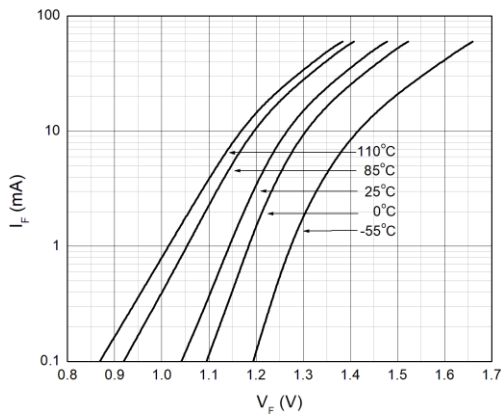

Fig.4 Collector Dark Current vs. Ambient Temperature

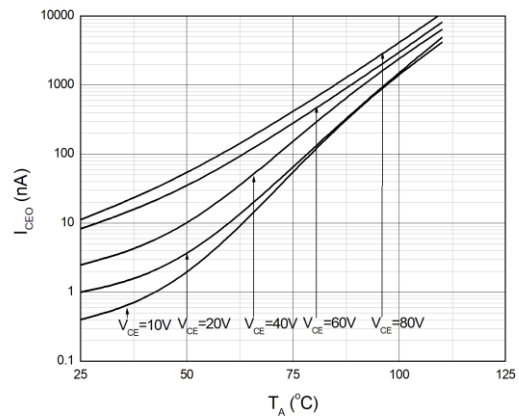

Fig.5 Collector Current vs. Collector-emitter Voltage

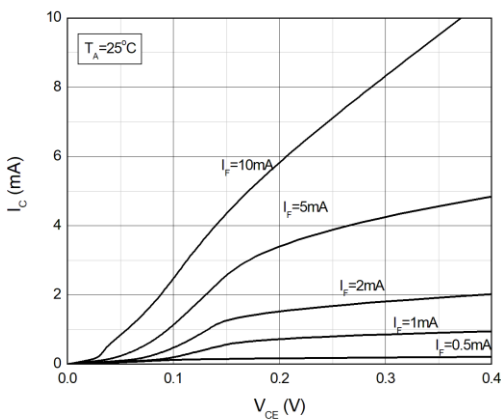
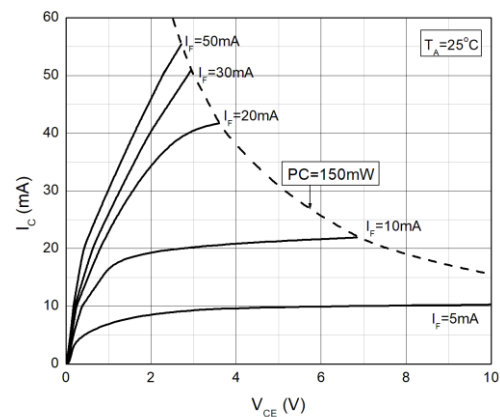

Fig.6 Collector Current vs. Collector-emitter Voltage



TWS100X Series

LSOP4, DC Input, Photo Transistor Coupler

CHARACTERISTIC CURVES

Fig.7 Normalized Current Transfer Ratio vs. Forward Current

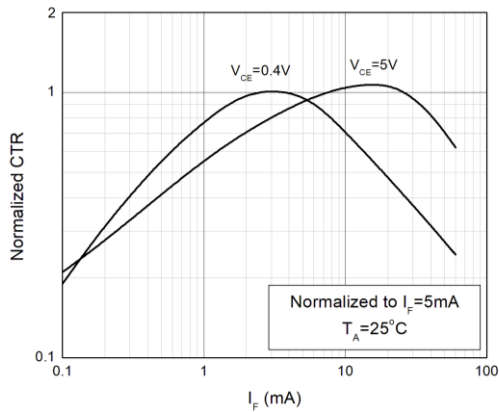

Fig.8 Normalized Current Transfer Ratio vs. Ambient Temperature

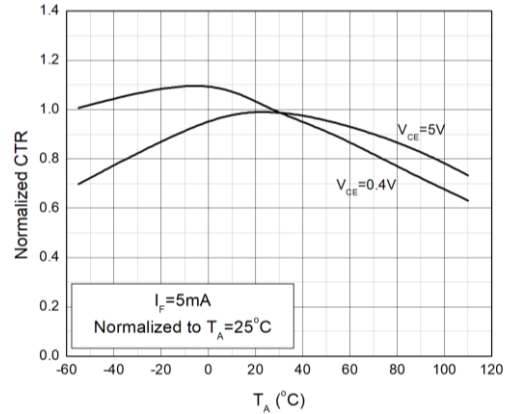

Fig.9 Collector-emitter Saturation Voltage vs. Ambient Temperature

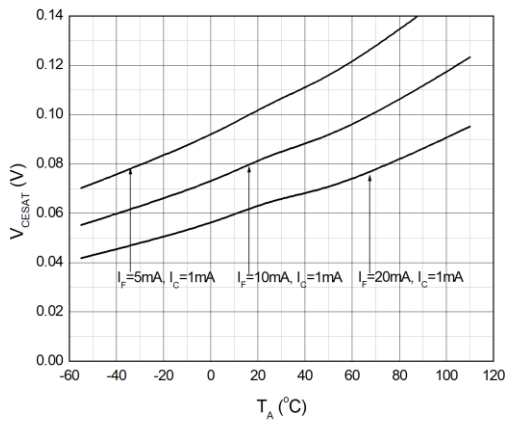

Fig.10 Switching Time vs. Load Resistance

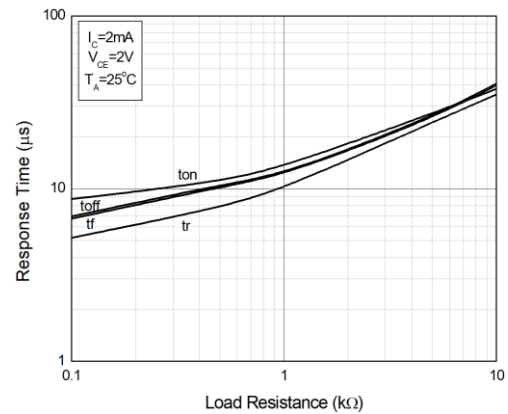
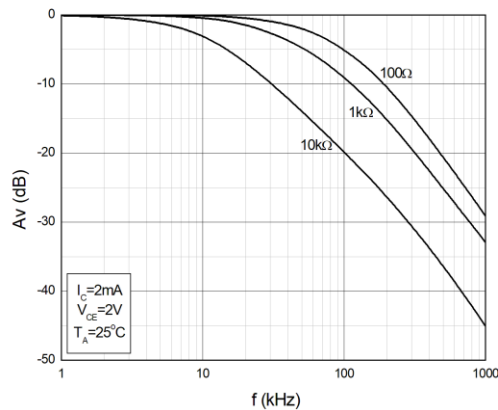

Fig.11 Frequency Response



TEST CIRCUITS

Fig.12 Test Circuits of Response Time

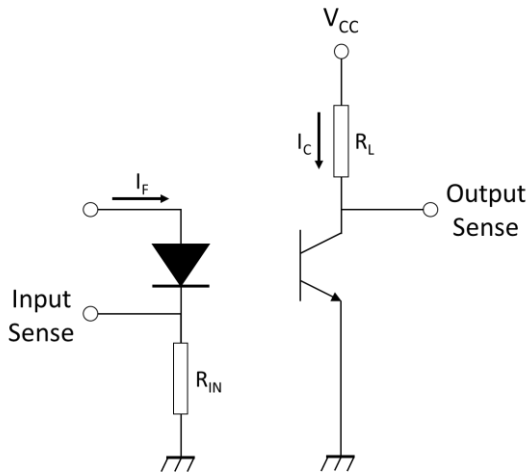

Fig.13 Curves of Response Time

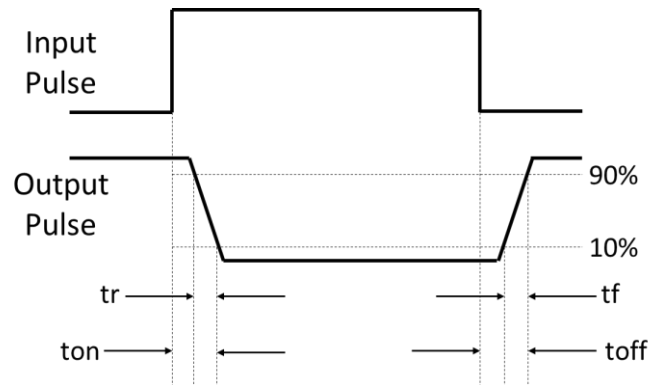
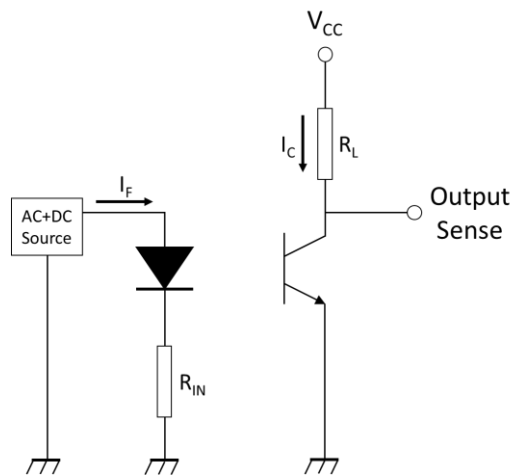

Fig.14 Test Circuits of Frequency Response



TWS100X Series

LSOP4, DC Input, Photo Transistor Coupler

PACKAGE DIMENSIONS (Dimensions in mm unless otherwise stated)

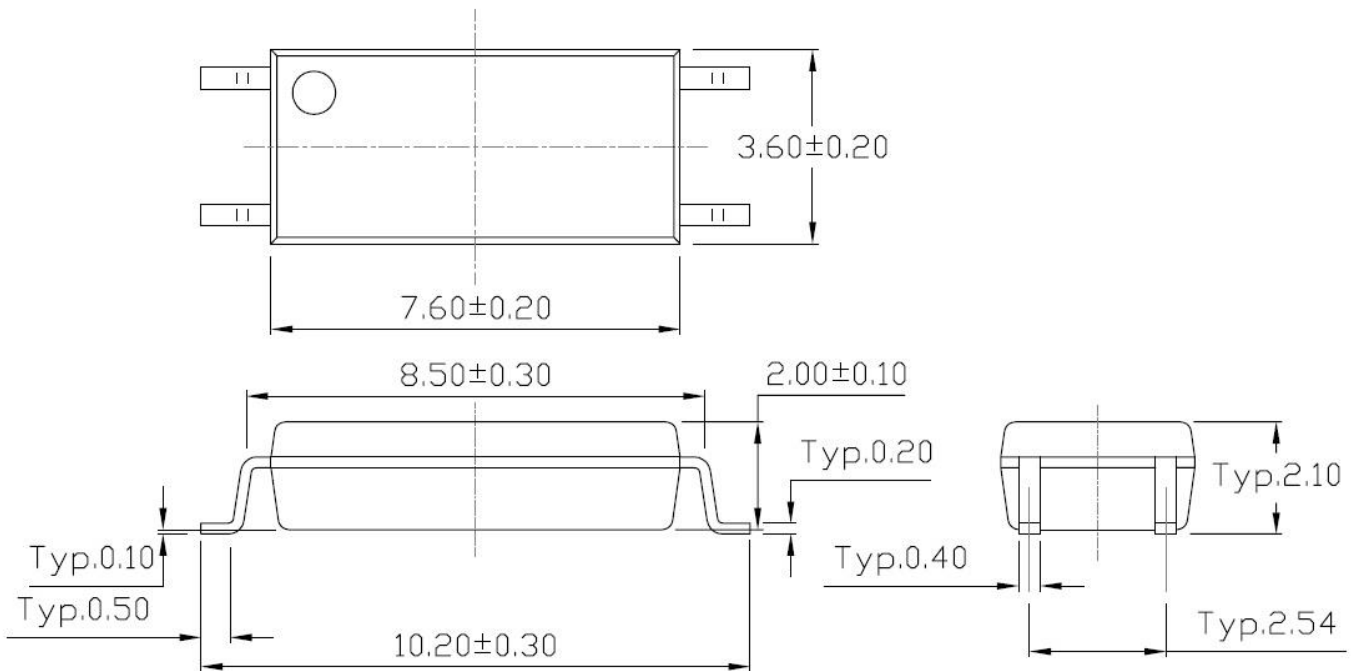

RECOMMENDED SOLDER MASK (Dimensions in mm unless otherwise stated)

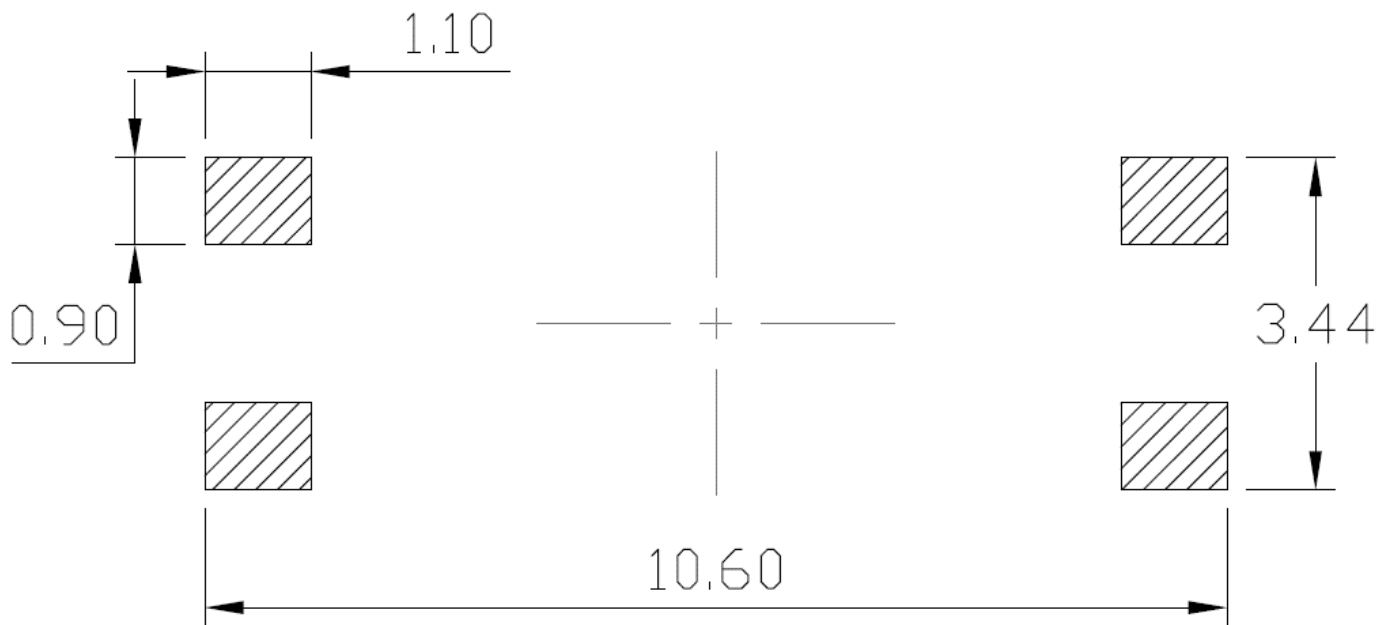

TWS100X Series

LSOP4, DC Input, Photo Transistor Coupler

REEL SPECIFICATIONS (Dimensions in mm unless otherwise stated)

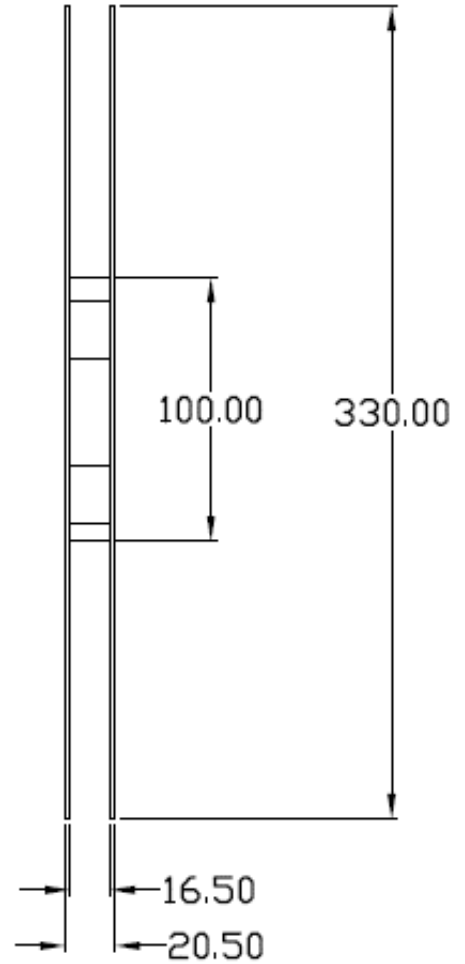
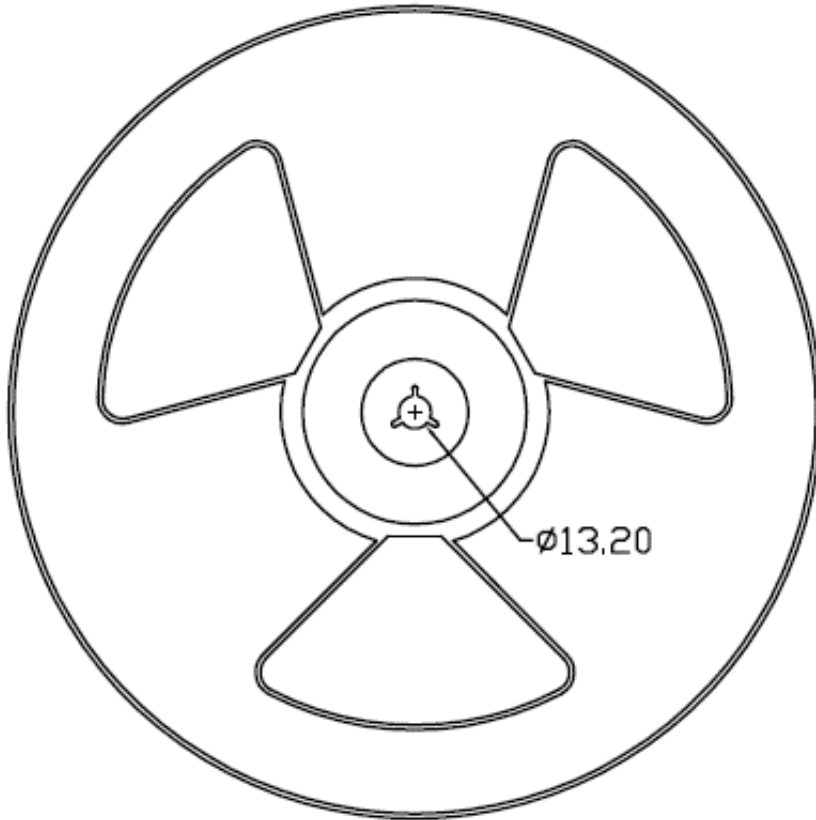

TWS100X Series

LSOP4, DC Input, Photo Transistor Coupler

BOX SPECIFICATIONS (Reel Type)

Inner Box

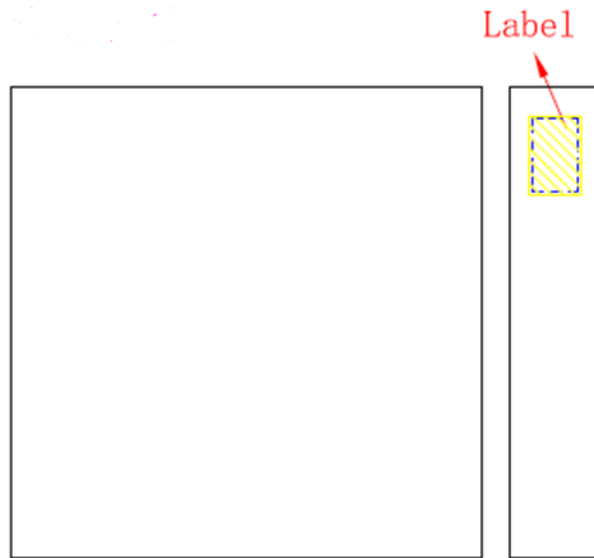

- L x W x H = 36cm x 36cm x 6.9cm

Outer Box

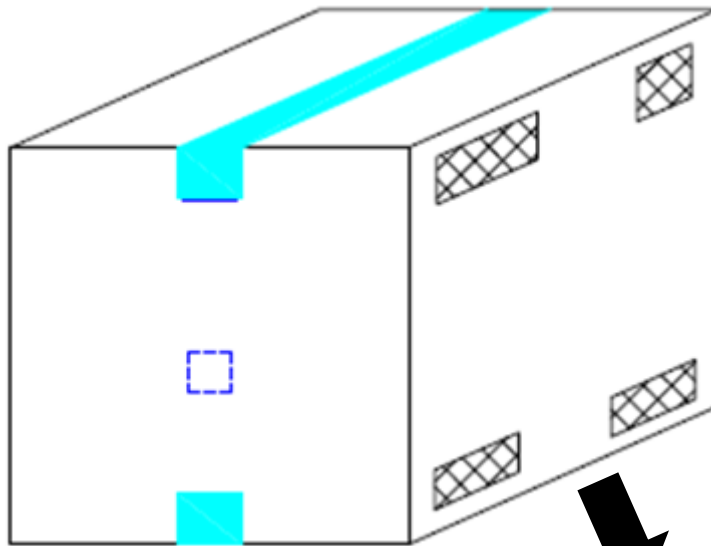

- L x W x H = 45cm x 38cm x 38cm

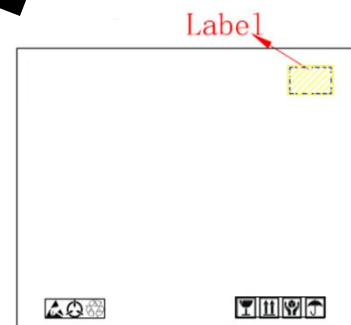

TWS100X Series

LSOP4, DC Input, Photo Transistor Coupler

ORDERING AND MARKING INFORMATION

MARKING INFORMATION

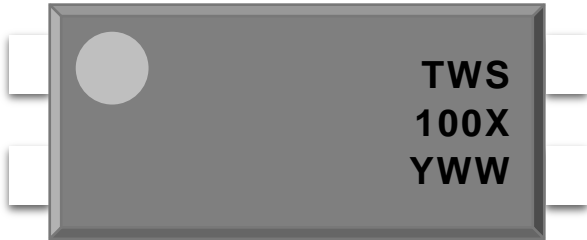





TWS : Company Abbr.
 100X : Part Number & Rank
 Y : Fiscal Year
 WW : Work Week

ORDERING INFORMATION

TWS100X

TWS – Company Abbr.
 100X – Rank (0/1/2/3/4/5/6/7/8/9)

LABEL INFORMATION

Part No.: TWS100X Bin Code: NA

 Lot No.: XXXXXXXXXX
 Date Code: XXXX
 QTY: XXXX PCS
  

PACKING QUANTITY

Option	Quantity	Quantity – Inner box	Quantity – Outer box
T1	3000 Units/Reel	3 Reels/Inner box	5 Inner box/Outer box = 45k Units

TEMPERATURE PROFILE OF SOLDERING

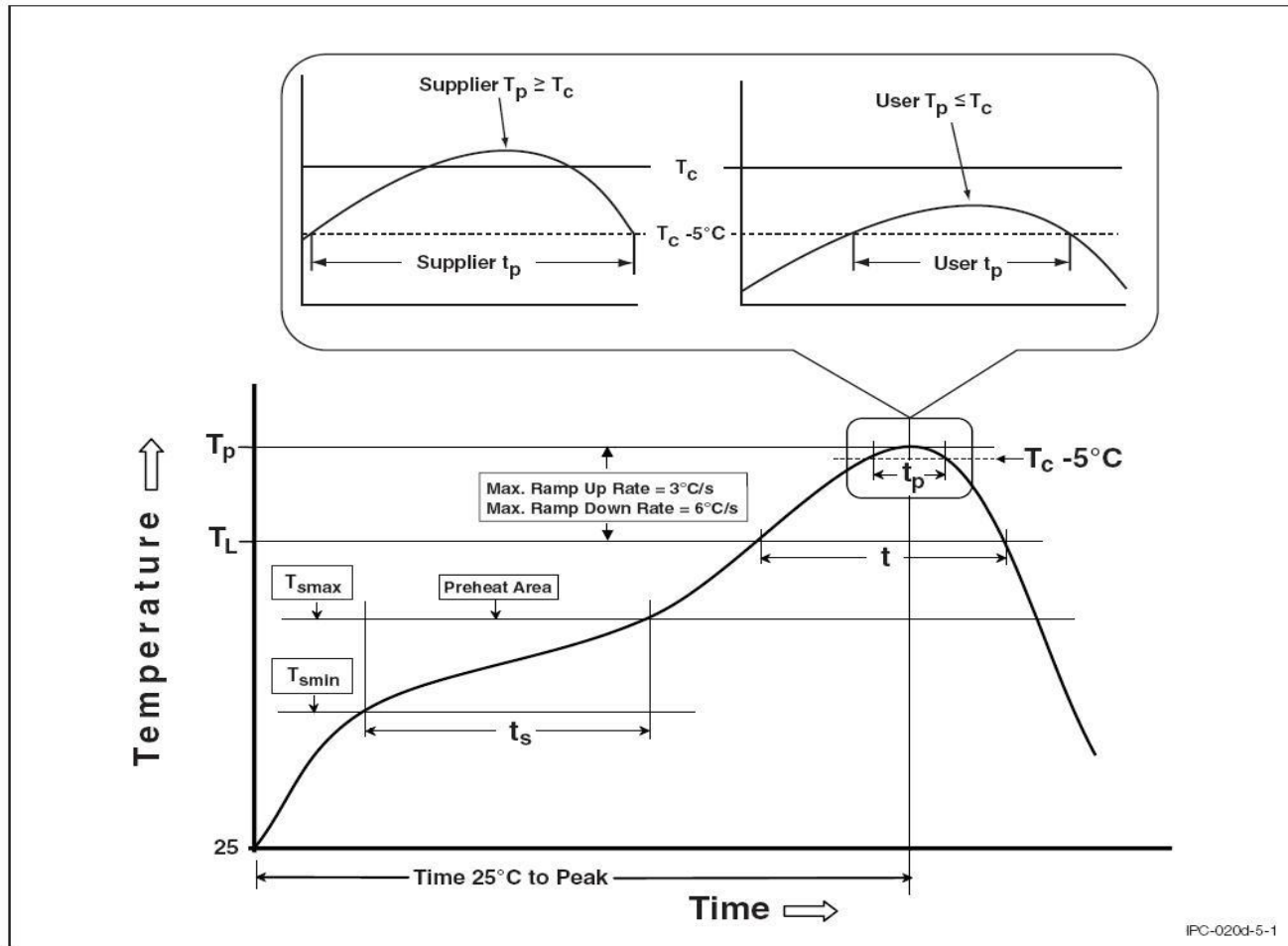
IR REFLOW SOLDERING (J-STWS-020D COMPLIANT)



Profile Feature	Sn-Pb Assembly Profile	Pb-Free Assembly Profile
Temperature Min. (T _{smin})	100	150°C
Temperature Max. (T _{smax})	150	200°C
Time (t _s) from (T _{smin} to T _{smax})	60-120 seconds	60-120 seconds
Ramp-up Rate (t _L to t _P)	3°C/second max.	3°C/second max.
Liquidous Temperature (T _L)	183°C	217°C
Time (t _L) Maintained Above (T _L)	60 – 150 seconds	60 – 150 seconds
Peak Body Package Temperature	235°C +0°C / -5°C	260°C +0°C / -5°C
Time (t _P) within 5°C of 260°C	20 seconds	30 seconds
Ramp-down Rate (T _P to T _L)	6°C/second max	6°C/second max
Time 25°C to Peak Temperature	6 minutes max.	8 minutes max.

LSOP4, DC Input, Photo Transistor Coupler

TEMPERATURE PROFILE OF SOLDERING

WAVE SOLDERING (JESD22-A111 COMPLIANT)

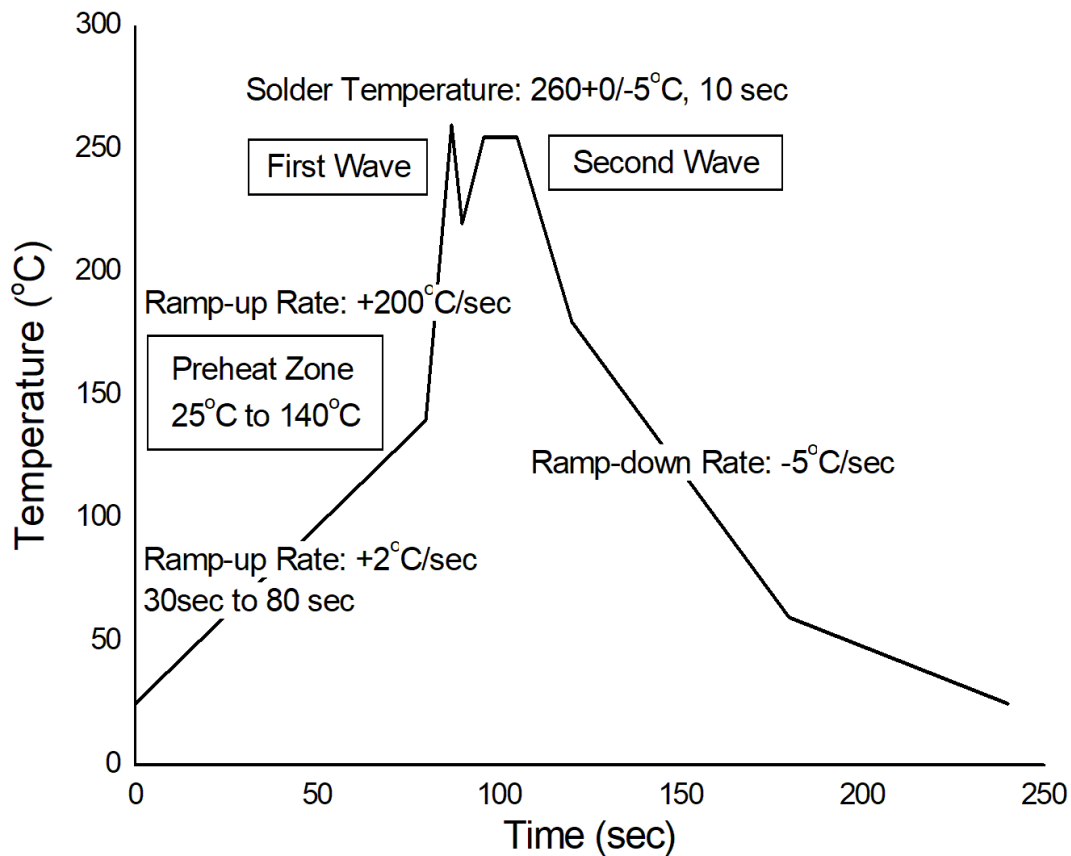

HAND SOLDERING BY SOLDERING IRON

Soldering Temperature	380+0/-5°C
Soldering Time	3 sec max.

Note 5. One time soldering is recommended for all soldering method.

Note 6. Do not solder more than three times for IR reflow soldering.